

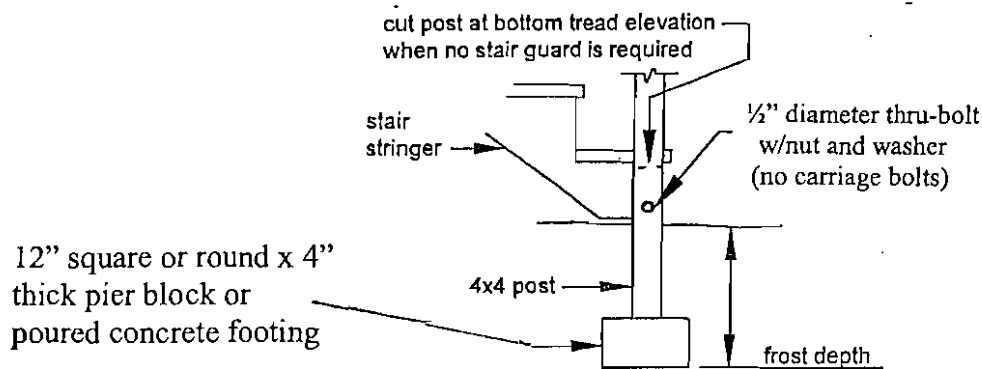

County of Henrico Building Inspections Department, Virginia
INTER-OFFICE MEMORANDUM

Residential Wood Deck Stair Stringer Attachment Details

Below are acceptable residential wood deck stair stringer attachment details approved by the Henrico County Building Inspections Department. Other alternate means of attachment may be acceptable but must be submitted to the individual county plan reviewer for approval. Stair stringer attachment details shall be attached to the building permit application for approval.



Stair Stringer Bearing At Grade

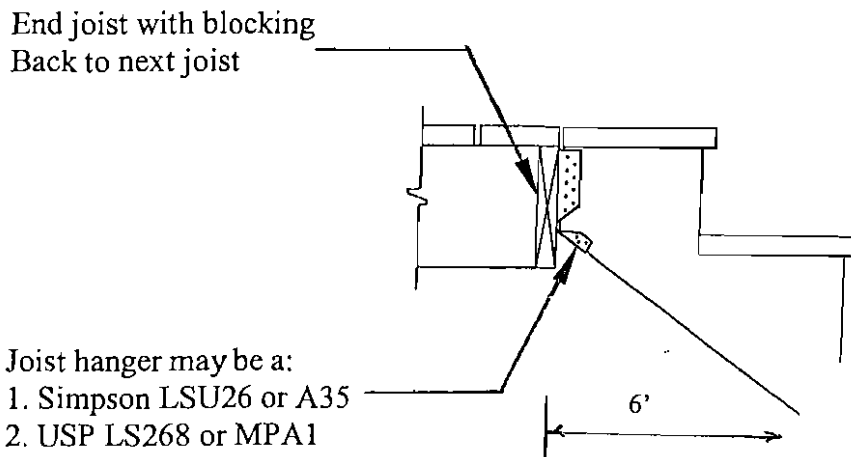

Stair Stringer Attachment Detail

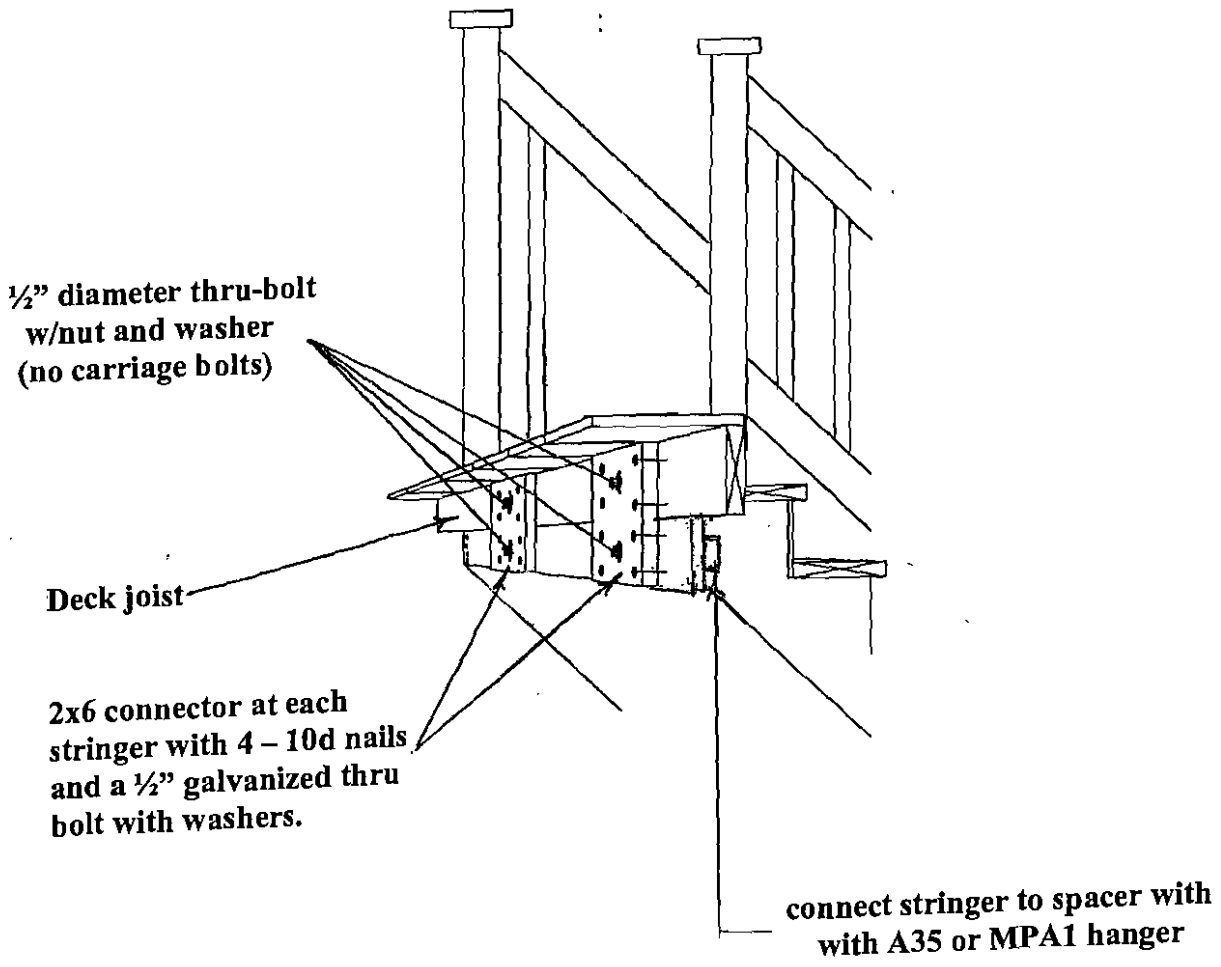

Stair Stringer Attachment Detail