

# COUNTY OF HENRICO DEPARTMENT OF PUBLIC UTILITIES

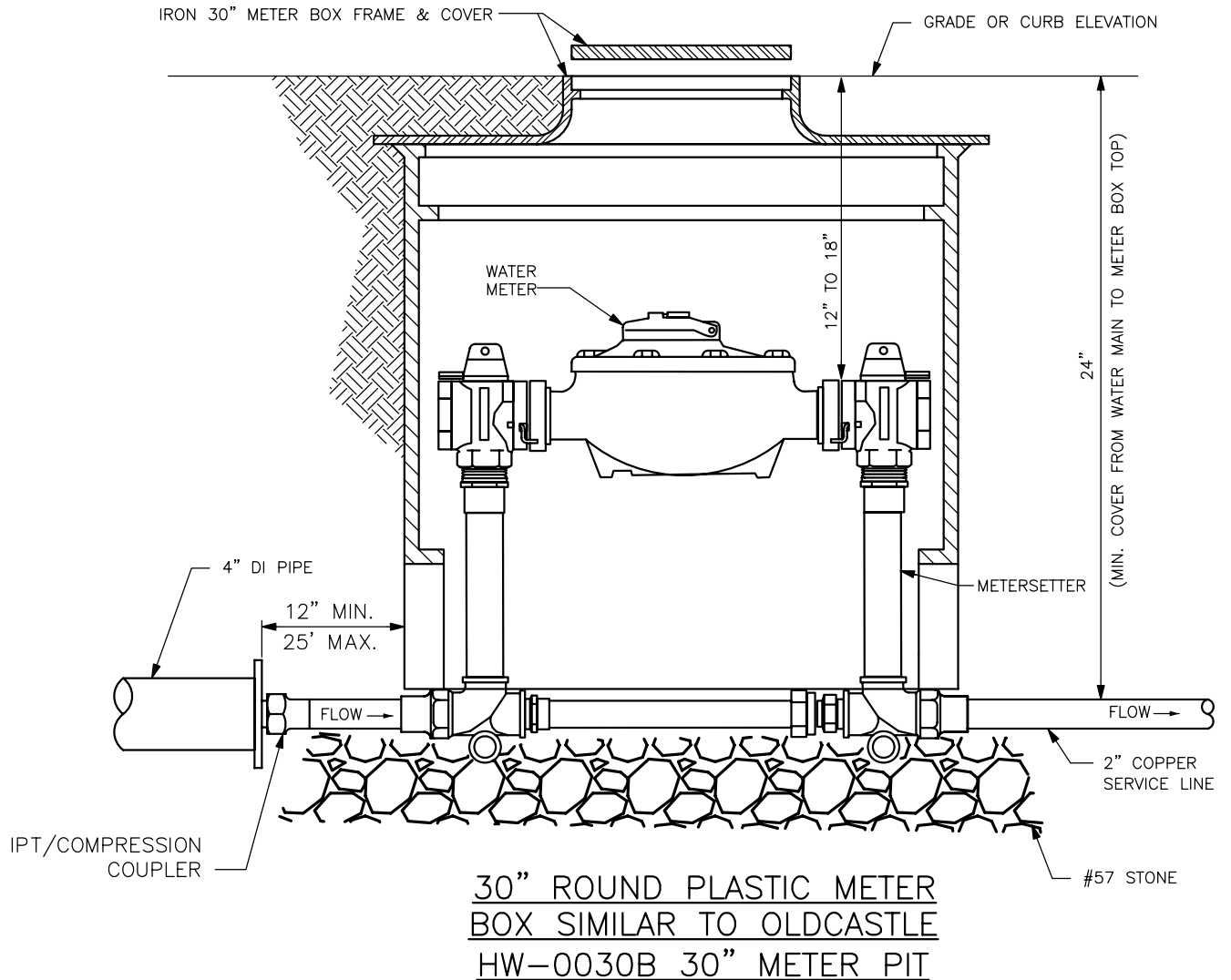

**NOTES:**

1. ALL WATER METERS TO BE FURNISHED & INSTALLED BY THE COUNTY.
2. ALL METERSSETTERS PROVIDED FOR 1-1/2" & 2" METERS SHALL HAVE REMOVABLE PACK JOINTS SUITABLE FOR COPPER PIPE.
3. ALL METERSSETTERS SHALL HAVE SADDLE NUTS, PADLOCK WINGS, AND SHALL BE SIMILAR TO FORD OR MUELLER.
4. BYPASS SHALL NOT BE PROVIDED.

REVISIONS  
06/20/2014

1 1/2" AND 2" METER SETTING

DRWG. NO.  
D-535-2